

**SK60F****THERMO-STOVES**

mm 680x660xh1450

CE EN -13240 certification

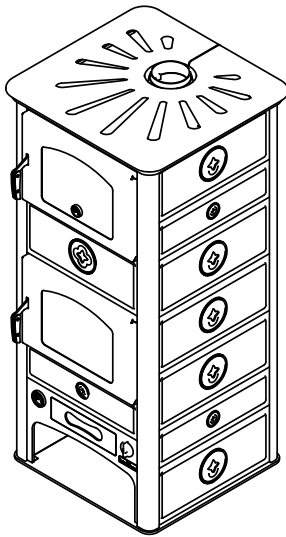

SK60F

Ceramic tiles white, bordeaux or serpentine stone

**STANDARD EQUIPMENT**

- above flue  $\varnothing$  150 mm
- safety heat exhaust outfitted for connection to a close circuit
- oven of mm 350x520xh240
- oven features: 1 grid + 1 baking pan
- pump thermostat
- primary air thermostatic regulation
- external flue air

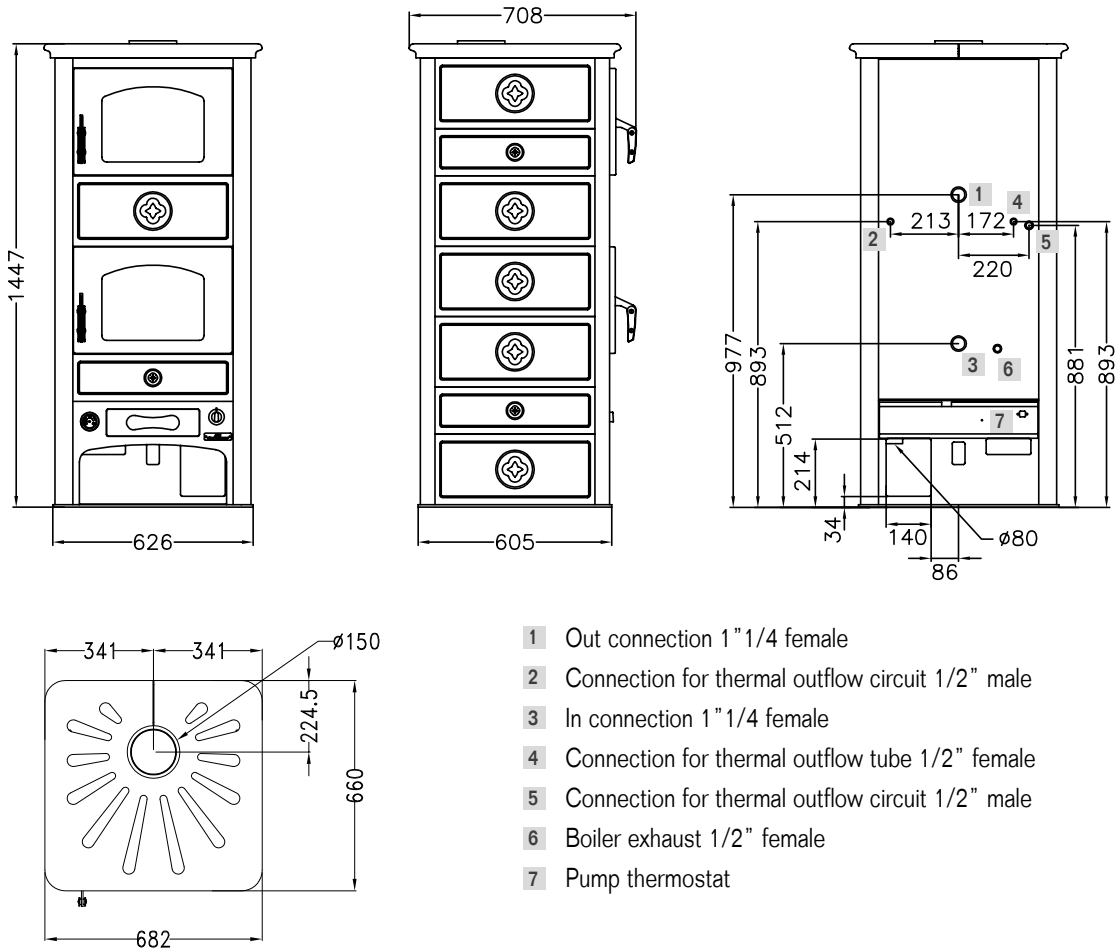

- 1 Out connection 1" 1/4 female
- 2 Connection for thermal outflow circuit 1/2" male
- 3 In connection 1" 1/4 female
- 4 Connection for thermal outflow tube 1/2" female
- 5 Connection for thermal outflow circuit 1/2" male
- 6 Boiler exhaust 1/2" female
- 7 Pump thermostat

**DATA SHEET**

Nominal heat output (max): 17.1 (26.5) kW	Nominal water heat output (max): 13.4 (20.5) kW
Mean content of CO to 13% O <sub>2</sub> : 0.06 %	Efficiency: 85.5 %
Maximum operating pressure: 1.5 bar	Boiler capacity: 26.5 Lt
Firebox capacity (LxPxH): 33x36x45 cm	Fill opening (LxH): 35x25 cm
Mean flue gas temperature: 205 °C	Flue gas mass flow: 15.2 g/s
Flue depression: mbar 0.12	Net weight/packaging included: kg 360/380